

OWNERS GUIDE TO INSTALLATION AND OPERATION

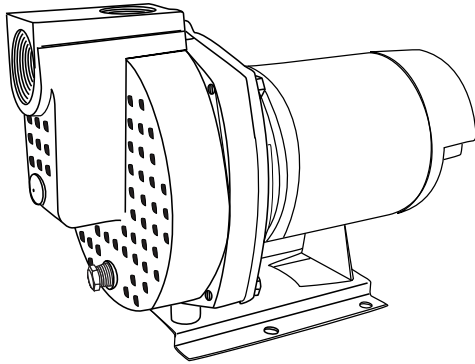

IL0175

SPJ, ELJ SERIES CENTRIFUGAL, IRRIGATION PUMP

READ THESE INSTRUCTIONS CAREFULLY

Read these installation instructions in detail before installing your pump. Be sure to check the following:

1. Be certain the motor is connected for the correct line voltage being used (check motor nameplate).
 2. Be certain the pump is completely primed before starting. Otherwise damage may occur to the seal.
- Every pump is tested before leaving the factory, and its performance depends largely on the installation.

GENERAL SAFETY INFORMATION

1. Follow all local electrical and safety codes, as well as the National Electrical Code (NEC) and the Occupational Safety and Health Act (OSHA).
2. Replace damaged or worn wiring cord immediately.
3. Do not kink power cable and never allow the cable to come in contact with oil, grease, hot surfaces, or chemicals.
4. Protect the power cable from coming in contact with sharp objects.
5. Be careful when touching the exterior of an operating motor - it may be hot enough to be painful or cause injury.
6. Make certain that the power source conforms to the requirements of your equipment.
7. **Always disconnect power source before performing any work on or near the motor or its connected load.** If the power disconnect point is out-of-sight, lock it in the open position and tag it to prevent unexpected application of power. Failure to do so could result in fatal electrical shock.
8. Do not handle the pump with wet hands or when standing in water as fatal electrical shock could occur. Disconnect main power before handling unit for **ANY REASON!**
9. Unit must be securely and adequately electrically grounded. This can be accomplished by wiring the unit to a ground metal-clad raceway system or by using a separate ground wire connected to the bare metal of the motor frame or other suitable means.
10. **⚠ WARNING RISK OF ELECTRIC SHOCK.** These pumps have not been investigated for use in swimming pool areas.

11. **⚠ WARNING** This product contains chemicals known to the State of California to cause cancer and birth defects or other reproductive harm.

NOTE: Pumps with the "UL" Mark and pumps with the "US" mark are tested to UL Standard UL778. CSA certified pumps are certified to CSA Standard C22.2 No. 108.

LOCATION

1. Pump can be located at the well or can be offset some distance away from the well. For best performance it should be located as close to the well as possible.
2. Location can be in the basement, a pit below ground, or in a pump house above ground.
3. Ventilation and drainage must be provided to prevent damage from moisture to the motor and pressure switch.
4. The pump and all piping must be protected from freezing.
5. Pump and pipe line must be drained when not in use if there is any danger of freezing.

WELL CONDITIONS

1. Wells should be pumped clean of all sand and foreign matter before installing the pump or damage may result to the operating parts.
2. The well must be able of supplying enough water to satisfy the capacity of the pump and water needs. The water level must not draw down below the maximum rated suction lift of the pump or loss of capacity and prime will result.

SUCTION LIMITATIONS

1. Shallow well installation is satisfactory where the suction lift is less than 25 feet. Suction lift is the vertical lift plus losses due to friction loss.
2. Suction lift varies depending upon elevation (altitude) and water temperature.

133264 C

PERFORMANCE

Model Number		HP	Suction Lift Ft.	Discharge Pressure PSI								Shut-Off Pressure PSI	Suction Pipe Tap	Disch. Pipe Tap
				10	15	20	25	30	35	40	45			
1 Phase	3 Phase	Capacity - U.S. Gallons per Minute												
SPJ07P1	SPJ07P3	3/4	5	56	48	42	37	29	21			41	2"	1-1/2"
			15	47	42	37	29	22	12		37			
			25	43	37	31	22	10			33			
SPJ10P1	SPJ10P3	1	5	58	53	48	43	38	32	23	11	48	2"	1-1/2"
			15	53	48	45	37	31	24	12	43			
			25	48	44	38	33	25	14		39			
SPJ15P1 ELJ15B1 SPJ15B1	SPJ15B3	1-1/2	5	78	77	74	70	62	53	43	30	47	2"	1-1/2"
			15	70	68	66	62	53	43	30	41			
			25	47	46	45	44	42	34		36			
SPJ20B1 ELJ20B1	SPJ20B3	2	5	86	84	81	77	71	62	52	40	50	2"	1-1/2"
			15	76	74	72	69	64	55	43	25	45		
			25	52	51	50	47	45	42	30		40		
SPJ30B1 ELJ30B1	SPJ30B3	3	5	88	86	85	84	80	73	64	53	54	2"	1-1/2"
			15	77	76	75	74	72	65	55	43	50		
			25	54	53	52	51	50	49	45	10	45		

Motor voltage: Single Phase: 3/4 - 2 HP - 115/230V 60Hz; Three Phase: 3/4 - 3 HP - 208-230/460V 50/60Hz
 Maximum Case Pressure: 100 PSI

SPECIFICATIONS (Figure 2)

HP	Type	Volts/Amps	Hz	RPM	Motor Voltage (Factory) Connected	Service Factor Motor Amps				Max Liquid Temp	Max Suction Lift
						Single Phase		Three Phase			
						115V	230V	230V	460V		
3/4	Single Ph	115/230	60	3450	115V	14.0	7.0			180°F	25 Ft.
1					18.0	9.0					
1-1/2					21.0	10.5	-	-			
2					25.0	12.5					
3					-	13.5					
3/4	Three Ph	208/-230/460	60/50	3450/2850	230V	-	-	3.5	1.75	180°F	25 Ft.
1								4.5	2.25		
1-1/2								5.7	2.85		
2								7.4	3.70		
3								9.8	4.90		

Suction lift varies, depending upon elevation (altitude) and water temperatures.

PIPING

1. Plastic or galvanized steel pipe may be used in the installation. Plastic pipe must have a minimum pressure rating 160 P.S.I. Galvanized steel pipe must be in good condition free of rust and scale. Threads should be sharp, cleanly cut.
2. Both the suction and discharge pipe should be no smaller than the corresponding tappings of the pump (See Figure 1). If long runs are encountered larger pipe should be used. Smaller pipe will reduce the capacity of the pump.
3. All joints and connections should have pipe sealing compound (male threads only) applied and drawn up tightly.

CAUTION: The entire system must be air and water tight for efficient operation.

PUMP INSTALLATION

1. Refer to Figures 3, 4, 5, and 6 for typical installations. If galvanized pipe is used, both the

- suction and discharge pipe should be supported at a point near the pump to avoid strains being placed on the pump.
2. The suction pipe should slope upwards from the water source to the pump. Locate the pump as close to the water as possible keeping the suction pipe as short as conditions permit.
3. Avoid dips or pockets in offset piping or air will accumulate at high points which will make priming difficult.
4. A foot valve located in the water or a check valve located as close to the water as possible will reduce priming time of the pump and help maintain prime. A strainer must be used on the suction line to filter out dirt and debris.
5. Install a gate valve and union in the discharge line. For removal of the pump for service, close the gate valve and disconnect the union.

CAUTION: Do not use a globe valve or other restricting type of valve at the discharge. This will seriously restrict the capacity of the pump.

TYPICAL INSTALLATIONS

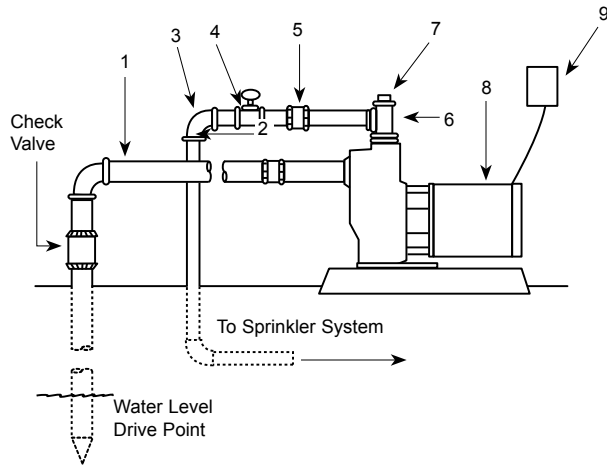

Figure 3 — From Ground Water “Drive Point”

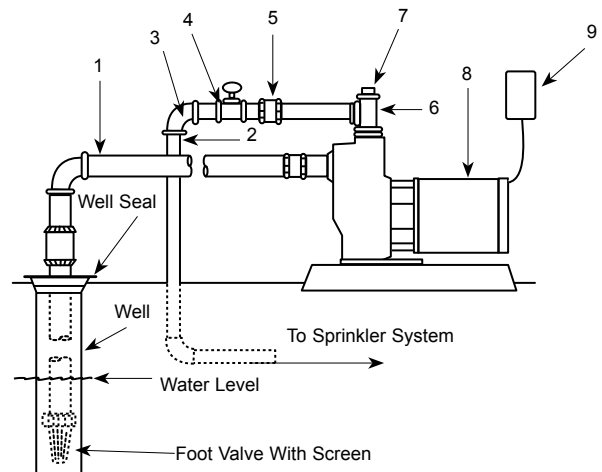

Figure 4 — From Ground Water “Well”

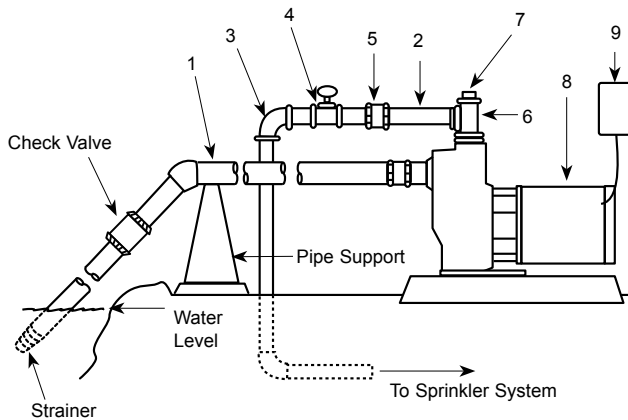

Figure 5 — From Surface Water “Lake, Stream, Cistern or Canal”

1 — Suction Pipe 2 — Discharge Pipe 3 — Elbow
6 — Discharge Tee 7 — Priming Plug 8 — Pump

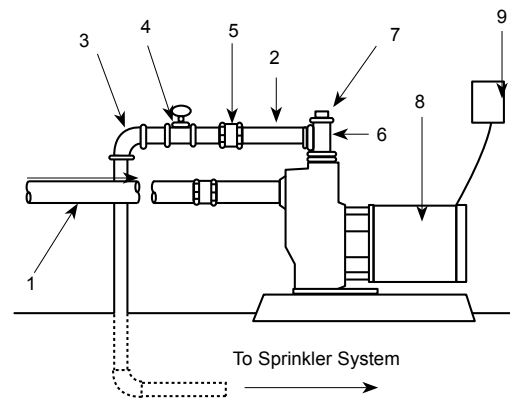

Figure 6 — From City Water Main

4 — Gate Valve 5 — Union
9 — Fuse Box

ELECTRICAL CONNECTIONS

GROUNDING

CAUTION: To reduce the risk of electric shock the motor must be securely and adequately grounded to a grounded metal raceway system, or by using a separate grounding wire connected to bare metal on the motor frame, or to the grounding screw located inside motor terminal box, or other suitable means. Refer to National Electric Code (NEC Article 250 {Grounding}) for additional information.

CAUTION: All wiring should be performed by a qualified electrician and in accordance with the national electric code and local electric codes.

WARNING: Failure to connect the motor frame to equipment grounding conductor by using green screw may result in serious electrical shock.

WIRING CONNECTIONS

1. This unit is not water proof and is not intended to be used in showers, saunas, or other potentially wet locations. The motor is designed to be

used in a clean dry location with access to an adequate supply of cooling air. Ambient temperature around the motor should not exceed 104F (40C). For outdoor installations motor must be protected by a cover that does not block airflow to and around the motor. This unit is not weatherproof nor is it able to be submersed in water, or any other liquid.

2. Single phase motors, 3/4 - 2 HP, are dual voltage and can be connected for 115V or 230V service. The 3 HP single phase motor is 230V only. Single phase motors are factory connected for 230V at the motor.
3. All three phase motors are 208-230/460 volts and are factory connected at the motor for 230 volts.

- If the motor wiring must be changed to conform to your specific voltage requirements then the motor should be rewired. For proper electrical connections, refer to the connection diagram located on the nameplate of the motor or one of the following diagrams. Make sure connections are correct for the voltage being supplied to the motor.

WARNING: Always disconnect power source before performing any work on or near the motor or its power source. Failure to do so could result in personal injury or fatal electrical shock.

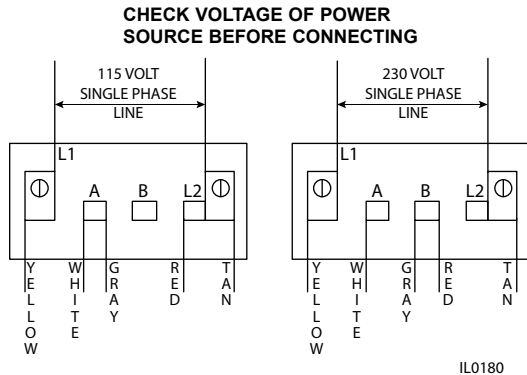

DO NOT CONNECT ANY GROUND WIRE TO THESE LEADS
Figure 7 — Wiring Diagram for Single Phase 3/4 - 2HP

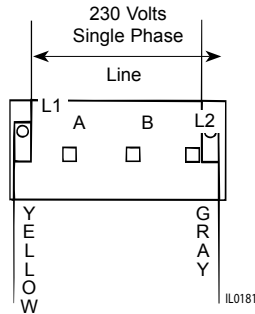

DO NOT CONNECT ANY GROUND WIRE TO THESE LEADS
Figure 7A — Wiring Diagram for Three Phase 3HP

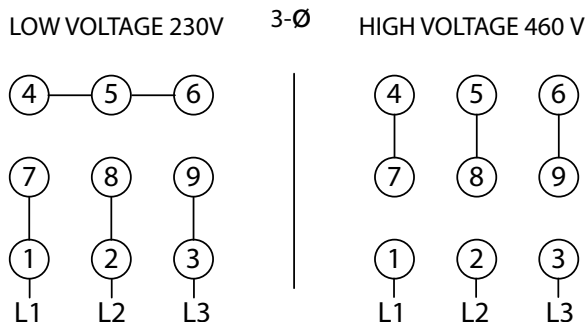

Connections for 3 Phase, 9 Leads

NOTE: To reverse rotation, interchange any two incoming line (power) leads

Figure 8 — Wiring Diagram for Three Phase

MOTOR PROTECTION

- All single-phase motors have built-in thermal protection for all voltages. The overload protects the motor against burnout from overload of low voltage, high voltage and other causes. The device is automatic and resets itself once the temperature has dropped to a safe point. Frequent tripping of the device indicates trouble in the motor or power lines and immediate attention is needed. The device should never be tampered with unless the trouble is located and corrected.

WARNING: Never examine, make wiring changes or touch the motor before disconnecting the main electrical supply switch. The thermal device may have opened the electrical circuit.

- Three-phase motors do not have built-in thermal protection. It is recommended that a properly sized magnetic or manual starter (both with properly sized heaters) be used with all three-phase motors. Install starters following instructions of the starter manufacturer. See Figure 10 for magnetic starter wiring program.
- All motors (single and three phase) should be equipped with a correctly fused disconnect switch to provide protection. Consult local or national electric codes for proper fuse protection based on motor data chart. See Figures 9 & 11.

MOTOR DATA (Figure 9)					
HP	Phase	Volts	Code Letter	Max Amps	Locked Rotor Amps
3/4	1	115	K	14.00	52.0
	1	230		7.00	26.0
	3	230		3.50	19.0
	3	460		1.75	9.5
1	1	115	L	18.00	70.0
	1	230	L	9.00	39.0
	3	230	K	4.50	26.9
	3	460	K	2.25	13.5
1-1/2	1	115	J	21.00	98.0
	1	230	J	10.50	49.0
	3	230	K	5.70	33.5
	3	460	K	2.85	16.8
2	1	115	H	25.00	116.0
	1	230	H	12.50	58.0
	3	230	K	7.40	44.0
	3	460	K	3.70	22.0
3	1	230	H	13.50	53.0
	3	230	D	9.80	48.0
	3	460	D	4.90	24.0

- Undersize wiring can cause motor failure (low voltage), frequent cut-out of motor overload protector, television interference and even fire. Make certain the wiring is adequately sized (Figure 11), well insulated and connected to a separate circuit outside the house in case of fire.

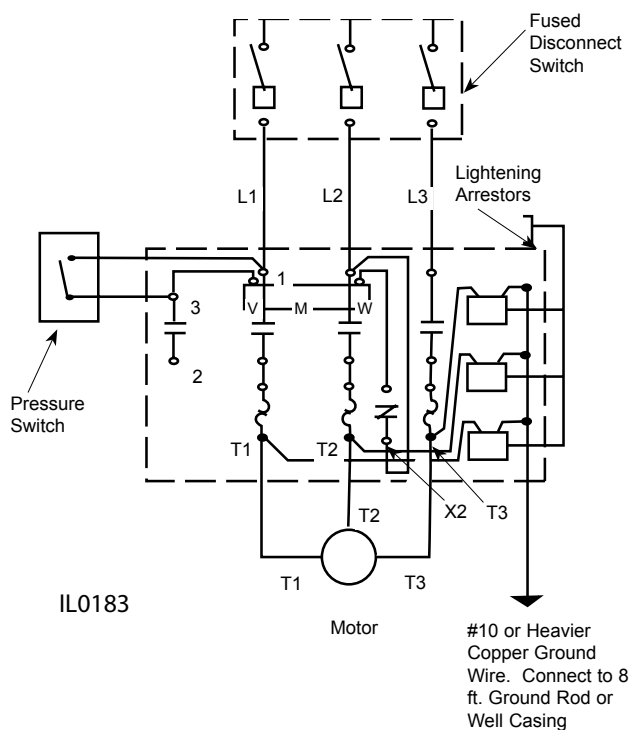

Figure 10 — Magnetic Starter Wiring Diagram — Three Phase

OPERATION

- When installation has been completed, remove the priming plug from the discharge tee (see Figures 3-6) and fill the pump body and suction pipe completely with water. No additional water will be needed for subsequent start-ups unless the pump body is drained.
- After the pump is turned on it will require 2-5 minutes before all air is evacuated from the suction line and water begins to flow. If there is no water after 10 minutes turn the pump off and check the following.
 - Any air leaks on the suction line must be eliminated.
 - Suction pipe inlet should be a minimum of 5 feet below the water level.
 - Total suction lift cannot be greater than 25 feet.
 - Any restrictions in the discharge line, such as a closed valve must be eliminated.

NOTE: Unit must be full of liquid before operating. Never run dry, or against a closed discharge. Dry running or running unit against a closed discharge will cause damage to the shaft seal. Do not pump dirty water or abrasive liquids, otherwise the same may occur as if running dry.

MOTOR ROTATION

- Single phase models are one rotation only (counterclockwise when facing the pump suction tapping) and cannot be reversed.
- Proper rotation of pump impeller is critical for three-phase pumps. Pump motor should turn counterclockwise (CCW) when facing pump suction tapping. Momentarily “bump” (apply power for less than a second) the motor to check for proper rotation. To change rotation on three-phase units, interchange any two incoming line (power) leads.

MAINTENANCE

Lubrication

- The pumps and motors require no lubrication. The ball bearings of the motor have been greased at the factory. Under normal operating conditions they should require no further greasing.

Freezing

- Drain the entire system if there is danger of freezing. A drain plug is provided at the bottom of the pump case for this purpose.

ROTARY SEAL ASSEMBLY REPLACEMENT

CAUTION: Make certain that the power supply is disconnected before attempting to service the unit! The rotary seal assembly must be handled carefully to avoid damaging the precision lapped faces of the sealing components.

See Parts List For Reference Numbers

- Disengage pump body (Ref. No. 10) from motor and mounting ring (Ref. No. 2) by removing bolts (Ref. No. 11).
- Remove diffuser bolts (Ref. No. 8) and remove diffuser (Ref. No. 7).
- Unthread impeller (Ref. No. 6). from motor shaft.

NOTE: To remove the impeller use a 9/16” open end wrench to hold the motor shaft. The shaft flat area is

Distance From Motor To Fuse Box, Meter or Electrical Outlet	Minimum Copper Wire Size Chart (Gauge) Figure 11																		
	Single Phase Motors									Three Phase Motors									
	3/4 HP		1 HP		1-1/2 HP		2 HP		3 HP	3/4 HP		1 HP		1-1/2 HP		2 HP		3 HP	
	115 Volt	230 Volt	115 Volt	230 Volt	115 Volt	230 Volt	115 Volt	230 Volt	230 Volt	230 Volt	460 Volt	230 Volt	460 Volt	230 Volt	460 Volt	230 Volt	460 Volt	230 Volt	460 Volt
0-50 Ft.	12	14	10	14	10	12	10	12	10	14	14	14	14	14	14	14	14	14	14
50-100 Ft.	12	14	10	14	8	12	8	12	10	14	14	14	14	14	14	14	14	14	14
100-150 Ft.	10	14	10	12	6	12	6	12	10	14	14	14	14	14	14	14	14	14	14
150-200 Ft.	10	12	8	12	*	10	*	10	10	14	14	14	14	12	14	12	14	12	14
200-300 Ft.	8	12	6	10	*	10	*	10	8	14	14	12	14	12	14	10	12	10	12
Fuse Size (Amps)	20	15	30	15	30	20	30	20	30	15	15	15	15	15	15	15	15	15	15

(*) Not economical to run in 115V, use 230V

located in the middle of the mounting ring.

- 4.. The rotary seal (Ref. No. 5) will come loose at this time. Use a screwdriver (or similar instrument) to pry the ceramic seal and rubber gasket from the recess of the mounting bracket.

CAUTION: *Be careful not to damage the motor shaft or recess surface.*

5. Clean the recess and motor shaft thoroughly.
6. Install the new rotary seal assembly:
 - a. Insert the ceramic seal and the rubber gasket into the recess.

NOTE: To help facilitate installation, apply a drop of liquid soap to the outside diameter of the rubber gasket. Make certain that the ceramic seal is kept clean and free of dirt and/or oil.

- b. Slip the remaining parts of the rotary seal assembly onto the motor shaft.
7. Replace the impeller and diffuser removed in Step B and C.
8. Reassemble the pump body to the motor and mounting bracket.

MOTOR REPLACEMENT

1. NEMA J motors can be replaced in the field with any standard NEMA J jet pump motor by referring to the following instructions and the attached parts list.
2. Follow steps A-D as outlined under rotary seal replacement to remove the pump body, diffuser, impeller and rotary seal.
3. Remove bolts (Ref. No. 3) that connect the motor (Ref. No.1) to the mounting ring (Ref. No. 2) and pull motor away.
4. Replace motor with standard NEMA J jet pump motor by positioning motor against the mounting frame and assembling with four 3/8" x 3/4" cap screws. The mounting base is connected at the bottom of the mounting frame with two 3/8" x 1/2" cap screws.
5. Follow steps 5, 6, 7 & 8 of Rotary Seal Assembly to reassemble the remainder of the pump.

NOTE: Because damage to the shaft seal is most likely to occur in disassembly, a new seal will be necessary.

SELF-PRIMER PUMP REPAIR PARTS
“SPJ/ELJ” SERIES
(For Pricing Refer To Repair Parts Price List)

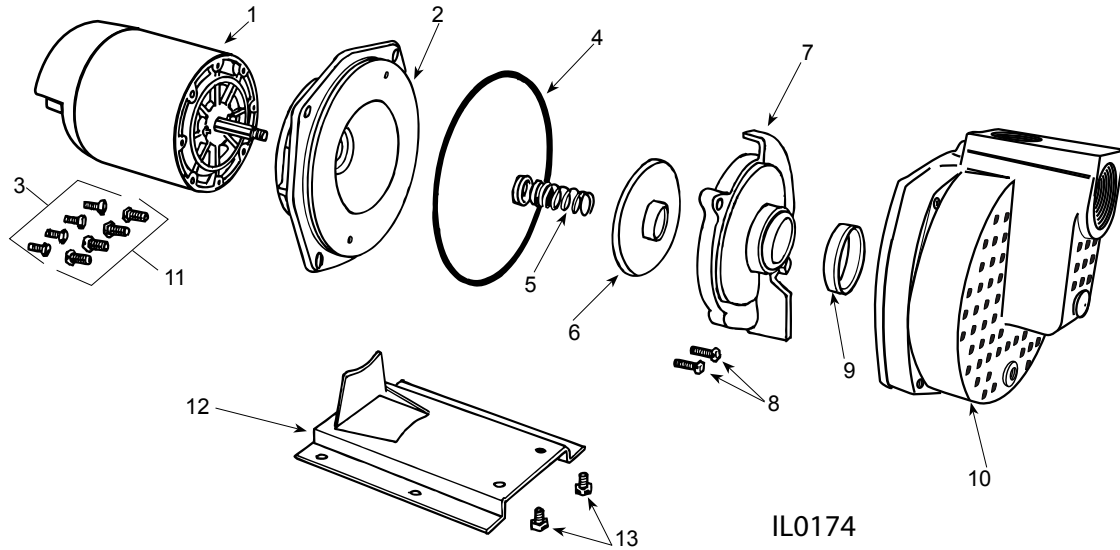

		HORSEPOWER	3/4	1	1-1/2	2	3
ITEM	SINGLE PHASE	MODEL NO.			SPJ15P1		
			SPJ07P1	SPJ10P1	SPJ15B1 ELJ15B1	SPJ20B1 ELJ20B1	SPJ30B1 ELJ30B1
	THREE PHASE		SPJ07P3	SPJ10P3	SPJ15B3	SPJ20B3	SPJ30B3
	DESCRIPTION	PART NO.	QTY				
1	Motor, Nema J - 1 PH		98J107	98J110	98J115	98J120	98J630
1	Motor, Nema J - 3 PH		98J307	98J310	98J315	98J320	023251
‡	Motor Cover w/Screws	021301R	1	1	1	1	1
	Screws, Cover	021302					
‡	Slinger, Washer	126905	1	1	1	1	1
2	Mounting Ring	133904	1	1	1	1	1
3	Hex Hd. Cap Screws 3/8 x 3/4"	*	4	4	4	4	4
4	Ring, Square Cut	133261	1	1	1	1	1
5	Seal, Rotary w/Spring	131100	1	1	1	1	1
6	Impeller, Plastic "P" Models		133646	135620	134138	—	—
6	Impeller, Brass "B" Models		—	—	133253	133255	138056
7	Diffuser w/ Insert	136469†	1	1	1	1	1
8	Hex Hd. Cap Screws 1/4 x 1"	*	2	2	2	2	2
9	Rubber Diffuser	133260	1	1	1	1	1
10	Pump Body	133362	1	1	1	1	1
11	Hex Hd. Cap Screws 7/16 x 1"	*	4	4	4	4	4
12	Base	134217A	1	1	1	1	1
13	Hex Hd. Cap Screws 3/8 x 1/2"	*	2	2	2	2	1

(*) Standard hardware item
(‡) Not shown
(†) Diffuser w/ 134240 Insert

TROUBLESHOOTING CHART		
Symptom	Possible Cause(s)	Corrective Action
Little or no discharge	1. Casing not initially filled with water	1. Fill pump casing
	2. Total head too high	2. Shorten suction lift and/or change head
	3. Suction lift too high, or too long	3. Lower suction lift, install foot valve and prime, or shorten length of suction line
	4. Impeller plugged	4. Clean
	5. Hole or air leak in suction line	5. Repair or replace; do not use Teflon tape; use pipe sealing compound
	6. Foot valve too small	6. Match foot valve to piping or install one size larger foot valve.
	7. Impeller damaged	7. Replace
	8. Foot valve or suction line not submerged deep enough in water	8. Submerge lower in water
	9. Insufficient inlet pressure or suction head	9. Increase inlet pressure by adding more water to tank or increasing back pressure
	10. Suction piping too small	10. Increase to pump inlet size or one size larger
	11. Motor wired incorrectly	11. Check wiring diagram
	12. Casing gasket leaking	12. Replace
	13. Suction or discharge line valves closed	13. Open
Pump will not deliver water or develop pressure	1. No priming water in casing	1. Fill pump casing
	2. Mechanical seal is leaking	2. Replace (see Rotary Seal Replacement)
	3. Leak in suction line	3. Repair or replace
	4. Discharge line is closed and priming air has nowhere to go	4. Open
	5. Suction line (or valve) is closed	5. Open
	6. Pump is down	6. Replace worn parts
	7. Foot valve is leaking	7. Replace foot valve
	8. Suction screen clogged	8. Clean or replace
Loss of suction	1. Air leak in suction line	1. Repair or replace
	2. Suction lift too high	2. Lower suction lift, install foot valve and prime
	3. Insufficient inlet pressure or suction head	3. Increase inlet pressure by adding more water to tank or increasing back pressure
	4. Clogged foot valve or strainer	4. Unclog
Pump vibrates and/or makes excessive noise	1. Mounting plate or foundation not rigid enough	1. Reinforce
	2. Foreign material in pump	2. Disassemble pump and clean
	3. Impeller damaged	3. Replace
	4. Worn motor bearings	4. Replace
	5. Suction lift too high	5. Lower suction lift, install foot valve and prime
Pump will not start or run	1. Improperly wired	1. Check wiring diagram on motor
	2. Blown fuse or open circuit breaker	2. Replace fuse or close circuit breaker
	3. Loose or broken wiring	3. Tighten connections, replace broken wiring
	4. Stone or foreign object lodged in impeller	4. Disassemble pump and remove foreign object
	5. Motor shorted out	5. Replace
	6. Thermal overload has opened circuit	6. Allow unit to cool, restart after reason for overload has been determined
Pumps leaks at shaft	1. Worn mechanical seal	1. Replace (see Rotary Seal Replacement)